

SIoux STEEL FARM BIN CATALOG



FARM BINS

DEPENDABLE STORAGE IN ALL CLIMATES



NOW OFFERING
10 YEAR
WARRANTIES
ON FARM BINS
SEE PAGE 7 FOR
DETAILS



SIoux BINS

Hooded Roof Vents

The steel or poly roof vent has a wide 15" x 15" inlet area for free air movement. Lap over design on the steel roof vent prevents leakage of moisture and condensation.

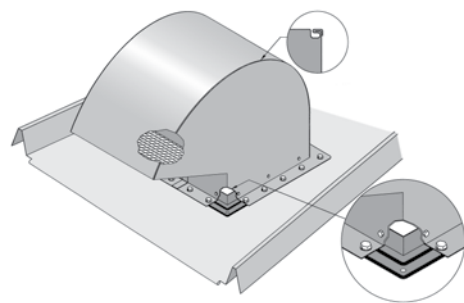

Solid Tieless Walk-In Door

Truly a walk-in door with no cross ties. Clear span opening allows anyone to walk in and out without having to crawl or unbolt any parts.



Compression Rings

On bins 24' to 48' in diameter, compression rings with locking collars crown the roof for added strength. Every Sioux bin comes with the optimum number of rings.



Roofs

The strongest roofs available! Our roofs stand up to high winds and northern snow loads, while protecting grain year round, keeping it fresh and in condition for years.

32-Degree Roof Slope

The 32-degree slope sheds moisture fast, both inside and outside of the panels.



Roof Ribs and Roof Edge

The roof ribs are deep, double-thick, overlapping and interlocked. The roof edge is rolled 340 degrees to stiffen panel edges and stand up to hard Midwest winds and reduce vibration that may cause failure. Sioux Steel's roofs are time tested and proven to be strong and durable throughout the years.



18' DIAMETER BIN

| Model # | SFN1803S | SFN1804S | SFN1805S |
|----------------------|----------|----------|----------|
| Rings | 3 | 4 | 5 |
| Eave Height (ft) | 11' | 14'8" | 18'4" |
| Peak Height (ft) | 16'8" | 20'4" | 24' |
| Eave Capacity | | | |
| w/13.25" Plenum | 2,117 | 2,900 | 3,683 |
| Maximum Bu. Capacity | | | |
| w/13.25" Plenum | 2,455 | 3,241 | 4,027 |
| Maximum Bu Capacity | | | |
| w/No Plenum | 2,687 | 3,470 | 4,253 |

| Model # | SFN1806S | SFN1807S | SFN1809S |
|----------------------|----------|----------|----------|
| Rings | 6 | 7 | 9 |
| Eave Height (ft) | 22' | 25'8" | 33' |
| Peak Height (ft) | 27'8" | 31'4" | 38'8" |
| Eave Capacity | | | |
| w/13.25" Plenum | 4,466 | 5,249 | 6,815 |
| Maximum Bu. Capacity | | | |
| w/13.25" Plenum | 4,814 | 5,600 | 7,173 |
| Maximum Bu Capacity | | | |
| w/No Plenum | 5,036 | 5,819 | 7,385 |

21' DIAMETER BIN

| Model # | SFN2103S | SFN2104S | SFN2105S |
|----------------------|----------|----------|----------|
| Rings | 3 | 4 | 5 |
| Eave Height (ft) | 11' | 14'8" | 18'4" |
| Peak Height (ft) | 17'7" | 21'3" | 24'11" |
| Eave Capacity | | | |
| w/13.25" Plenum | 2,882 | 3,948 | 5,013 |
| Maximum Bu. Capacity | | | |
| w/13.25" Plenum | 3,418 | 4,489 | 5,559 |
| Maximum Bu Capacity | | | |
| w/No Plenum | 3,735 | 4,822 | 5,866 |

| Model # | SFN2106S | SFN2107S | SFN2109S |
|----------------------|----------|----------|----------|
| Rings | 6 | 7 | 9 |
| Eave Height (ft) | 22' | 25'8" | 33' |
| Peak Height (ft) | 28'7" | 32'3" | 39'7" |
| Eave Capacity | | | |
| w/13.25" Plenum | 6,079 | 7,144 | 9,311 |
| Maximum Bu. Capacity | | | |
| w/13.25" Plenum | 6,629 | 7,700 | 9,840 |
| Maximum Bu Capacity | | | |
| w/No Plenum | 6,932 | 7,997 | 10,128 |

24' DIAMETER BIN

| Model # | SFN2403S | SFN2404S | SFN2405S | SFN2406S |
|----------------------|----------|----------|----------|----------|
| Rings | 3 | 4 | 5 | 6 |
| Eave Height (ft) | 11' | 14'8" | 18'4" | 22' |
| Peak Height (ft) | 18'3" | 21'11" | 25'7" | 29'3" |
| Eave Capacity | | | | |
| w/13.25" Plenum | 3,764 | 5,156 | 6,548 | 7,940 |
| Maximum Bu. Capacity | | | | |
| w/13.25" Plenum | 4,566 | 5,964 | 7,362 | 8,760 |
| Maximum Bu Capacity | | | | |
| w/No Plenum | 5,001 | 6,399 | 7,762 | 9,154 |

| Model # | SFN2407S | SFN2408S | SFN2409S | SFN2410S |
|----------------------|----------|----------|----------|----------|
| Rings | 7 | 8 | 9 | 10 |
| Eave Height (ft) | 25'8" | 29'4" | 33' | 36'8" |
| Peak Height (ft) | 32'11" | 36'7" | 40'3" | 43'11" |
| Eave Capacity | | | | |
| w/13.25" Plenum | 9,331 | 10,723 | 12,115 | 13,507 |
| Maximum Bu. Capacity | | | | |
| w/13.25" Plenum | 10,158 | 11,556 | 12,954 | 14,352 |
| Maximum Bu Capacity | | | | |
| w/No Plenum | 10,546 | 11,991 | 13,329 | 14,721 |

Manway

You won't have to wonder if you can make it through the manway when you're out in the elements with lots of layers of clothing on. It's the most user-friendly manway!

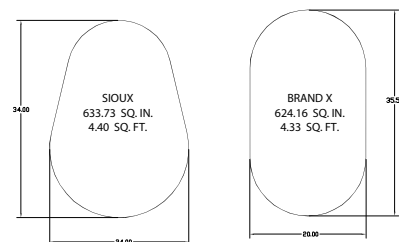

Fill Caps

Fill caps are designed for one-handed control of the cap. Ground control or flat top-style caps are optional for permanent installation of cross augers or spouting.

4" Corrugation

Corrugation on sheets reduce pressure on the sidewalls and allows grain to flow easily down bin wall with less resistance. Fewer sheets cover a wider area, lowering construction costs.

LARGEST MAN-WAY IN THE INDUSTRY!

Sioux Steel's man-way is 24" x 34", giving you the ability to maneuver easily through the opening.

Service You Can Count On!



ACCESSORIES

Ladder & Cage System

Manufactured from sturdy, galvanized steel tube that fit the bin side wall with each ring. An economical way to gain access to the roof of the bin while keeping your safety in mind.



Floor & Floor Support System

Designed to develop equal air pressure under the entire floor surface, floor supports are available in 20, 18 or 16 gauge, galvanized steel formed with ten vertical ribs to support grain depths up to 37 feet.



Crosscut or standard perforated available.

Stairs

Installed on bin in either direction. A step, 20" wide, is mounted 6" from the bin wall producing a 26" wide walkway. Stair, intermediate, twin, ladder or end platforms are available.



Springland U Trough Power Sweep

High capacity unloading with 5000-6000 BPH unloading capacity. Elevator style paddle type sweep wheel keeps sweep arm moving in tough unloading conditions. Easily installed under standard height drying and aeration floor systems.



27' DIAMETER BIN

| Model # | SFN2704S | SFN2705S | SFN2706S |
|----------------------|----------|----------|----------|
| Rings | 4 | 5 | 6 |
| Eave Height (ft) | 14'8" | 18'4" | 22' |
| Peak Height (ft) | 22'10" | 26'6" | 30'2" |
| Eave Capacity | | | |
| w/13.25" Plenum | 6,526 | 8,287 | 10,049 |
| Maximum Bu. Capacity | | | |
| w/13.25" Plenum | 7,676 | 9,445 | 11,215 |
| Maximum Bu Capacity | | | |
| w/No Plenum | 8,189 | 9,951 | 11,712 |

| Model # | SFN2707S | SFN2708S | SFN2709S |
|----------------------|----------|----------|----------|
| Rings | 7 | 8 | 9 |
| Eave Height (ft) | 25'8" | 29'4" | 33' |
| Peak Height (ft) | 33'10" | 37'6" | 41'2" |
| Eave Capacity | | | |
| w/13.25" Plenum | 11,810 | 13,572 | 15,333 |
| Maximum Bu. Capacity | | | |
| w/13.25" Plenum | 12,984 | 14,753 | 16,523 |
| Maximum Bu Capacity | | | |
| w/No Plenum | 13,474 | 15,235 | 16,997 |

30' DIAMETER BIN

| Model # | SFN3004S | SFN3005S | SFN3006S |
|----------------------|----------|----------|----------|
| Rings | 4 | 5 | 6 |
| Eave Height (ft) | 14'8" | 18'4" | 22' |
| Peak Height (ft) | 23'10" | 27'6" | 31'2" |
| Eave Capacity | | | |
| w/13.25" Plenum | 8,056 | 10,231 | 12,406 |
| Maximum Bu. Capacity | | | |
| w/13.25" Plenum | 9,633 | 11,818 | 14,002 |
| Maximum Bu Capacity | | | |
| w/No Plenum | 10,267 | 12,442 | 14,617 |

| Model # | SFN3007S | SFN3008S | SFN3009S |
|----------------------|----------|----------|----------|
| Rings | 7 | 8 | 9 |
| Eave Height (ft) | 25'8" | 29'4" | 33' |
| Peak Height (ft) | 34'10" | 38'6" | 42'2" |
| Eave Capacity | | | |
| w/13.25" Plenum | 14,580 | 16,775 | 18,930 |
| Maximum Bu. Capacity | | | |
| w/13.25" Plenum | 16,186 | 18,371 | 20,555 |
| Maximum Bu Capacity | | | |
| w/No Plenum | 16,791 | 18,966 | 21,141 |

33' DIAMETER BIN

| Model # | SFN3304S | SFN3305S | SFN3306S |
|----------------------|----------|----------|----------|
| Rings | 4 | 5 | 6 |
| Eave Height (ft) | 14'8" | 18'4" | 22' |
| Peak Height (ft) | 24'8" | 28'4" | 32' |
| Eave Capacity | | | |
| w/13.25" Plenum | 9,748 | 12,379 | 15,011 |
| Maximum Bu. Capacity | | | |
| w/13.25" Plenum | 11,847 | 14,491 | 17,134 |
| Maximum Bu Capacity | | | |
| w/No Plenum | 12,613 | 15,245 | 17,957 |

| Model # | SFN3307S | SFN3308S | SFN3309S |
|----------------------|----------|----------|----------|
| Rings | 7 | 8 | 9 |
| Eave Height (ft) | 25'8" | 29'4" | 33' |
| Peak Height (ft) | 35'8" | 39'4" | 43' |
| Eave Capacity | | | |
| w/13.25" Plenum | 17,692 | 20,274 | 22,905 |
| Maximum Bu. Capacity | | | |
| w/13.25" Plenum | 19,777 | 22,329 | 25,063 |
| Maximum Bu Capacity | | | |
| w/No Plenum | 20,507 | 23,139 | 25,770 |

Power Sweep

Posi-shift style power sweep system uses internally engaged gear box to eliminate moving parts and chain drive. Available in 8 and 10 inch sizes for all bin diameters.

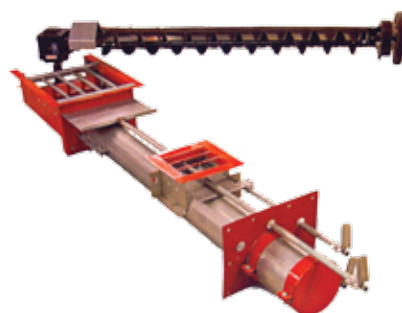

LJI Floor Support System

- LJI Floor Supports provide:
- 1) Strength per square foot of floor
 - 2) Unobstructed air movement
 - 3) Ease of erection and stability



Transition

The aerodynamically engineered "channel-flow" shape delivers air between the fan and bin plenum. Multiple sizes fit every size fan and heater.



Centrifugal Fans

Adjustable legs on these quiet fans allow for easy leveling and support while giving more flexibility for adjusting to inconsistencies in a concrete pad.

Axial Fans

Airflow is increased by not allowing air to blow back through the blade and the housing for greater efficiency.



Dependable Grain Storage!



OUR HISTORY

Sioux Steel Heritage

Founded over 90 years ago, our mission continues to be "Your complete satisfaction as a customer is our best advertisement."

Whether your order for Sioux products is large or small, frequent or occasional, we feel a definite obligation to provide you with high-quality products and outstanding service.

Now in our fourth generation as a family-owned company, we continue to extend our guarantee of satisfaction to every order entrusted to us.

Sioux Steel also makes these quality products:

- Pro•Tec Engineered Buildings
- Commercial Bins
- Livestock Equipment
- Grain Handling Equipment
- And more...

"Sioux Steel Company has been rewarded for over 90 years of doing business by creating valued products and providing successful manufacturing operations and products for our employees, dealers, and our customer... the farmer. At the same time we remain a strong supporter of our community and committed to staying involved for the long haul. We do not take anything for granted and are continually looking for improvement and expansion in every facet of our business."

Phil Rysdon, President, Sioux Steel Company
Third Generation Owner

"We don't just want our customers to be satisfied... We want them to be delighted to do business with us..."

Scott Rysdon, CEO, Sioux Steel Company
Fourth Generation Owner

✓ **Quality Bin Storage**

✓ **10 Year Warranty**

✓ **Local Dealers**

✓ **Excellent Service**

✓ **Proven Product**



10 Year Warranty

Based in Sioux Falls, SD, Sioux Steel knows how drastically weather can alter any structure.

Sioux Steel offers the longest warranty in the industry on farm bins. Our 10 year warranty comes standard on every farm bin. Plus, there is no additional cost for this feature.

You get a great quality bin with a warranty that is the longest in the industry, giving you peace of mind.

Sioux Steel stands behind its products and wants you to have the best possible experience.

For warranty questions or concerns, please contact:

Sioux Steel Company

196 1/2 East 6th Street

PO Box 1265

Sioux Falls, SD 57101-1265

Toll Free: 800-557-4689

Local: 605-336-1750



36' DIAMETER BIN

| Model # | SFN3604S | SFN3605S | SFN3606S | SFN3607S |
|----------------------|----------|----------|----------|----------|
| Rings | 4 | 5 | 6 | 7 |
| Eave Height (ft) | 14'8" | 18'4" | 22' | 25'8" |
| Peak Height (ft) | 25'8" | 29'4" | 33' | 36'8" |
| Eave Capacity | | | | |
| w/13.25" Plenum | 11,601 | 14,733 | 17,864 | 20,996 |
| Maximum Bu. Capacity | | | | |
| w/13.25" Plenum | 14,326 | 17,471 | 20,617 | 23,762 |
| Maximum Bu Capacity | | | | |
| w/No Plenum | 15,237 | 18,368 | 21,597 | 24,631 |

| Model # | SFN3608S | SFN3609S | SFN36102S |
|----------------------|----------|----------|-----------|
| Rings | 8 | 9 | 10 |
| Eave Height (ft) | 29'4" | 33' | 36'8" |
| Peak Height (ft) | 40'4" | 44' | 47'8" |
| Eave Capacity | | | |
| w/13.25" Plenum | 24,127 | 27,259 | 30,390 |
| Maximum Bu. Capacity | | | |
| w/13.25" Plenum | 26,908 | 30,053 | 33,199 |
| Maximum Bu Capacity | | | |
| w/No Plenum | 27,763 | 30,895 | 34,026 |

42' DIAMETER BIN

| Model # | SFN4204S | SFN4205S | SFN4206S | SFN4207S |
|----------------------|----------|----------|----------|----------|
| Rings | 4 | 5 | 6 | 7 |
| Eave Height (ft) | 14'8" | 18'4" | 22' | 25'8" |
| Peak Height (ft) | 27'4" | 31' | 34'8" | 38'4" |
| Eave Capacity | | | | |
| w/13.25" Plenum | 15,790 | 20,053 | 24,315 | 28,578 |
| Maximum Bu. Capacity | | | | |
| w/13.25" Plenum | 20,117 | 24,398 | 28,680 | 32,961 |
| Maximum Bu Capacity | | | | |
| w/No Plenum | 21,354 | 25,616 | 29,878 | 34,141 |

| Model # | SFN4208S | SFN42092S | SFN42102S |
|----------------------|----------|-----------|-----------|
| Rings | 8 | 9 | 10 |
| Eave Height (ft) | 29'4" | 33' | 36'8" |
| Peak Height (ft) | 42' | 45'8" | 49'4" |
| Eave Capacity | | | |
| w/13.25" Plenum | 32,840 | 37,102 | 41,365 |
| Maximum Bu. Capacity | | | |
| w/13.25" Plenum | 37,243 | 41,524 | 45,806 |
| Maximum Bu Capacity | | | |
| w/No Plenum | 38,403 | 42,666 | 46,928 |

48' DIAMETER BIN

| Model # | SFN4804S | SFN4805S | SFN4806S | SFN4807S |
|----------------------|----------|----------|----------|----------|
| Rings | 4 | 5 | 6 | 7 |
| Eave Height (ft) | 14'8" | 18'4" | 22' | 25'8" |
| Peak Height (ft) | 29'2" | 32'10" | 36'6" | 40'2" |
| Eave Capacity | | | | |
| w/13.25" Plenum | 20,624 | 26,191 | 31,749 | 37,326 |
| Maximum Bu. Capacity | | | | |
| w/13.25" Plenum | 27,082 | 32,674 | 38,266 | 43,858 |
| Maximum Bu Capacity | | | | |
| w/No Plenum | 28,693 | 34,261 | 39,828 | 45,395 |

| Model # | SFN4808S | SFN48092S | SFN48102S |
|----------------------|----------|-----------|-----------|
| Rings | 8 | 9 | 10 |
| Eave Height (ft) | 29'4" | 33' | 36'8" |
| Peak Height (ft) | 43'10" | 47'6" | 51'2" |
| Eave Capacity | | | |
| w/13.25" Plenum | 42,893 | 48,460 | 54,028 |
| Maximum Bu. Capacity | | | |
| w/13.25" Plenum | 49,450 | 55,530 | 60,634 |
| Maximum Bu Capacity | | | |
| w/No Plenum | 50,962 | 56,530 | 62,097 |

Sioux Steel Quality Products!

SIoux STEEL FARM BIN CATALOG

FOR MORE INFORMATION AND YOUR NEAREST DEALER, CONTACT:

SIoux STEEL COMPANY

P.O. Box 1265

SIoux FALLS, SD 57101-1265

1-800-557-4689

605-336-1750

WWW.SIouxSTEEL.COM



FARM BIN METRIC SPECIFICATIONS

| Bin Model | Diameter | Ring | Maximum Capacity (Cubic Feet) | Maximum Metric Tons 800 kg/m ³ | Maximum Metric Tons 721 kg/m ³ | Maximum Metric Tons 640 kg/m ³ | Eave Height (Meters) | Peak Height (Meters) | Maximum Capacity (Cubic Meters) |
|-----------|----------|------|-------------------------------|-------------------------------------------|-------------------------------------------|-------------------------------------------|----------------------|----------------------|---------------------------------|
| SFN1803S | 18 FT | 3 | 3,159 | 76 | 69 | 61 | 3.35 | 5.08 | 90 |
| SFN1804S | (5.46m) | 4 | 4,082 | 98 | 89 | 79 | 4.47 | 6.20 | 116 |
| SFN1805S | | 5 | 5,006 | 120 | 109 | 97 | 5.59 | 7.32 | 142 |
| SFN1806S | | 6 | 5,929 | 143 | 129 | 115 | 6.71 | 8.43 | 168 |
| SFN1807S | | 7 | 6,852 | 165 | 149 | 132 | 7.82 | 9.55 | 195 |
| SFN1809S | | 9 | 8,699 | 209 | 189 | 168 | 10.06 | 11.79 | 247 |
| SFN2103S | 21 FT | 3 | 4,390 | 106 | 95 | 85 | 3.35 | 5.36 | 125 |
| SFN2104S | (6.37m) | 4 | 5,647 | 136 | 123 | 109 | 4.47 | 6.48 | 160 |
| SFN2105S | | 5 | 6,904 | 166 | 150 | 133 | 5.59 | 7.60 | 196 |
| SFN2106S | | 6 | 8,160 | 196 | 177 | 158 | 6.71 | 8.71 | 232 |
| SFN2107S | | 7 | 9,417 | 226 | 204 | 182 | 7.82 | 9.83 | 267 |
| SFN2109S | | 9 | 11,930 | 286 | 259 | 230 | 10.06 | 12.06 | 338 |
| SFN2403S | 24 FT | 3 | 5,853 | 141 | 127 | 113 | 3.35 | 5.59 | 166 |
| SFN2404S | (7.24m) | 4 | 7,494 | 180 | 163 | 145 | 4.47 | 6.68 | 213 |
| SFN2405S | | 5 | 9,135 | 219 | 198 | 176 | 5.59 | 7.80 | 259 |
| SFN2406S | | 6 | 10,777 | 259 | 234 | 208 | 6.71 | 8.92 | 306 |
| SFN2407S | | 7 | 12,418 | 298 | 269 | 239 | 7.82 | 10.03 | 352 |
| SFN2408S | | 8 | 14,059 | 337 | 305 | 271 | 8.94 | 11.15 | 399 |
| SFN2409S | | 9 | 15,700 | 377 | 340 | 303 | 10.06 | 12.27 | 445 |
| SFN2410S | | 10 | 17,341 | 415 | 375 | 335 | 11.18 | 13.39 | 492 |
| SFN2704S | 27 FT | 4 | 9,634 | 231 | 209 | 186 | 4.47 | 6.96 | 273 |
| SFN2705S | (8.19m) | 5 | 11,712 | 281 | 254 | 226 | 5.59 | 8.08 | 332 |
| SFN2706S | | 6 | 13,789 | 331 | 299 | 266 | 6.71 | 9.20 | 391 |
| SFN2707S | | 7 | 15,866 | 381 | 344 | 306 | 7.82 | 10.31 | 450 |
| SFN2708S | | 8 | 17,943 | 430 | 389 | 346 | 8.94 | 11.43 | 509 |
| SFN2709S | | 9 | 20,021 | 480 | 434 | 386 | 10.06 | 12.55 | 567 |
| SFN3004S | 30 FT | 4 | 12,079 | 290 | 262 | 233 | 4.47 | 7.26 | 343 |
| SFN3005S | (9.10m) | 5 | 14,644 | 351 | 317 | 282 | 5.59 | 8.38 | 415 |
| SFN3006S | | 6 | 17,208 | 413 | 373 | 332 | 6.71 | 9.50 | 488 |
| SFN3007S | | 7 | 19,773 | 474 | 428 | 381 | 7.82 | 10.62 | 560 |
| SFN3008S | | 8 | 22,337 | 536 | 484 | 430 | 8.94 | 11.73 | 633 |
| SFN3009S | | 9 | 24,902 | 597 | 539 | 480 | 10.06 | 12.85 | 706 |
| SFN3304S | 33 FT | 4 | 14,839 | 356 | 322 | 286 | 4.47 | 7.52 | 421 |
| SFN3305S | (10.01m) | 5 | 17,942 | 430 | 389 | 346 | 5.59 | 8.63 | 509 |
| SFN3306S | | 6 | 21,045 | 505 | 456 | 405 | 6.71 | 9.75 | 596 |
| SFN3307S | | 7 | 24,148 | 579 | 523 | 465 | 7.82 | 11.18 | 684 |
| SFN3308S | | 8 | 27,252 | 653 | 590 | 525 | 8.94 | 11.99 | 772 |
| SFN3309S | | 9 | 30,355 | 728 | 657 | 585 | 10.06 | 13.11 | 860 |
| SFN3604S | 36 FT | 4 | 17,926 | 430 | 388 | 345 | 4.47 | 7.82 | 508 |
| SFN3605S | (10.91m) | 5 | 21,619 | 518 | 468 | 416 | 5.59 | 8.94 | 613 |
| SFN3606S | | 6 | 25,312 | 607 | 548 | 488 | 6.71 | 10.06 | 717 |
| SFN3607S | | 7 | 29,005 | 695 | 628 | 559 | 7.82 | 11.48 | 822 |
| SFN3608S | | 8 | 32,698 | 784 | 708 | 630 | 8.94 | 12.29 | 926 |
| SFN3609S | | 9 | 36,391 | 872 | 788 | 701 | 10.06 | 13.41 | 1,032 |
| SFN36102S | | 10 | 40,084 | 961 | 868 | 772 | 11.18 | 14.53 | 1,136 |
| SFN4204S | 42 FT | 4 | 25,124 | 602 | 544 | 484 | 4.47 | 8.33 | 712 |
| SFN4205S | (12.73m) | 5 | 30,151 | 723 | 653 | 581 | 5.59 | 9.45 | 854 |
| SFN4206S | | 6 | 35,177 | 843 | 762 | 677 | 6.71 | 10.57 | 997 |
| SFN4207S | | 7 | 40,204 | 964 | 870 | 774 | 7.82 | 11.68 | 1,139 |
| SFN4208S | | 8 | 45,230 | 1,084 | 979 | 871 | 8.94 | 12.80 | 1,281 |
| SFN4209S | | 9 | 50,257 | 1,204 | 1,088 | 967 | 10.06 | 13.92 | 1,424 |
| SFN42102S | | 10 | 55,283 | 1,325 | 1,197 | 1,064 | 11.18 | 15.04 | 1,566 |
| SFN4804S | 48 FT | 4 | 33,762 | 809 | 731 | 650 | 4.47 | 8.89 | 957 |
| SFN4805S | (14.55m) | 5 | 40,328 | 967 | 873 | 776 | 5.59 | 10.01 | 1,142 |
| SFN4806S | | 6 | 46,893 | 1,124 | 1,015 | 903 | 6.71 | 11.13 | 1,328 |
| SFN4807S | | 7 | 53,458 | 1,281 | 1,157 | 1,029 | 7.82 | 12.24 | 1,514 |
| SFN4808S | | 8 | 60,023 | 1,438 | 1,299 | 1,155 | 8.94 | 13.36 | 1,702 |
| SFN4809S | | 9 | 66,588 | 1,596 | 1,441 | 1,282 | 10.06 | 14.48 | 1,886 |
| SFN48102S | | 10 | 73,153 | 1,753 | 1,583 | 1,408 | 11.18 | 15.60 | 2,072 |

CAPACITIES ARE ESTIMATES AND NOT GUARANTEED. Capacities are calculated at 27 degree angle of repose (grain 1" below eave), based on ASAE Standard: S413.1 and include 6% compaction. All bins are designed for storage of grain and/or free-flowing materials not exceeding 48 lb/ft³ (52 lb/ft³ including compaction). Storage of grains heavier than 52 lbs-per cubic foot (including compaction), must be approved by Sioux Steel. We reserve the right to change specifications without notice.

